

## **Logitilt - when lifting and/or tilting**

The Logitilt is an efficient and ergonomic solution, when transporting, lifting and/or tilting boxes and crates.

The design focuses on the safety and ergonomic working conditions of the user. The ergonomic correct handle ensures the user a relaxed hold. The Logitilt can tilt boxes and crates up to 90°. The user does not have to bend down or stretch up to reach the components in the bottom of the crate or box - this applies both to standing and sitting work positions.

The tilting degree can be set, so that the Logitilt automatically stops in the same angle each time.

High quality is ensured through an extended test programme and in cooperation with experts in Health and Safety.



### Technical Specifications

The Logilift can carry, lift and tilt crates and boxes up to 90°, and the working height can be varied.

The ergonomic handle can be turned to the side and locked, so that the user has free access to the contents of the crate or box.

The Logitilt can be set to stop automatically in the same angle each time.

Optimum safety for the user through

- foot protectors
- parking brake
- safety valve
- emergency stop

Strong construction ensures a long operating life and low maintenance costs.



The straddle Logitilt can handle many different pallet types, also closed pallets.



Remote control for the tilt function.



Perfect working position when emptying boxes and crates - sitting as well as standing.

Product (measured in mm)	LT 1001TE	LT 1001TES
Capacity in kg	1000	
Height, tilted	750-950	
Lifting height	275	
Fork length	800/1150	
Overall height with handle	1055	
Overall height	680	
Overall width	780	166 + b <sub>4</sub>
Fork span	560	
Fork width	163	
Overall length by 800 mm forks	1425	
Length without forks	590	
Run-in length	712	735
Overall height	h <sub>t</sub> + l	
Lowered height	85	
Load centre	max. l/2	
Load centre	min. 200 - max. 420	
Width between legs	850-942, 942-1124, 1124-1306	
Pump motor	0,8 KW 12V	
Lifting speed lift/tilt	4 s/14 s	
Lowering speed lift/tilt	3 s/11 s	
Weight by 800 mm forks (without battery)	177 kg	251 kg



The handle can be turned to the side, so that the user has free access to the contents of the crate or box.



The Logitilt being used in the component industry.

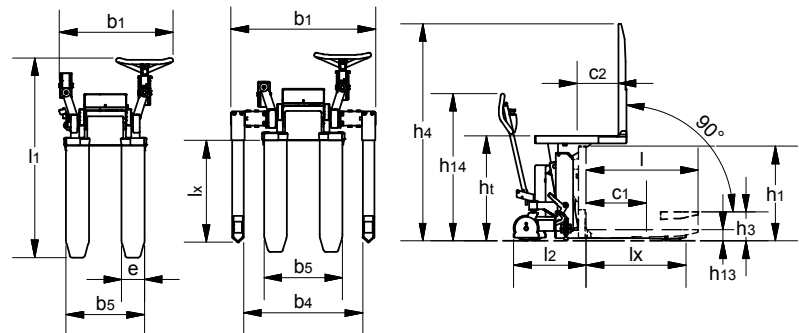

LT 1001TE

LT 1001TES

We also offer tailor-made solutions.

Please ask for further information or visit our website [www.logitrans.com](http://www.logitrans.com)