



Weighing Scales:

HH20ST, Stainless Steel Pallet Truck Scale (2200kg)



The HH20ST is a high quality stainless steel pallet truck with a weighing scale, German designed and manufactured in the EU. Constructed from high grade stainless steel and with an IP67/68 waterproof rating, it is suitable for **pharmaceutical, food and chemical** industries, as well as many types of **wet** applications.



Waterproof:

Fitted with 4 high quality load cells with a waterproof rating of IP68 and a digital weigh indicator, housed in a stainless steel case, with an IP67 rating.

Digital Display Indicator:

High weighing accuracy of 0.02% of applied load, measured in 500g increments. Features include automatic & manual zero setting, switch between net and gross weight, 100% tare, multiple tare, piece counting, pre-set or control limit value, automatic shut-off, large user friendly LCD display with backlight.



optional thermal printer

optional foot brake

Additional:

- Long operating time of approx. 50 hours between charges
- Fork span 560mm (Euro pallets) or 690mm (UK Chep pallets)
- Operating temperatures -10°C to $+40^{\circ}\text{C}$
- Smooth blasted finish: few hiding places for bacteria
- Charge via mains plug-in
- 1 year warranty (parts & labour, UK Mainland)
- *Optional:* RS232 interface
- *Optional:* roll paper thermal printer
- *Optional:* foot brake



Units 10 & 11 Bridgwater Court, Oldmixon Crescent, Weston-super-Mare BS24 9AY

Tel: 01934 621777 Email: sales@howardhandling.co.uk Web: www.howardhandling.co.uk



HH20ST

Specification:

Lifting Capacity	kg	2200
Weight, Including Battery	kg	150
Forks, Lowered Height	mm	95
Forks, Raised Height	mm	205
Fork Span	mm	560 or 690
Fork Length	mm	1150
Individual Fork Width	mm	170
Gap Between Forks	mm	220 or 350
Wheels		Nylon
Battery (Sealed, Maintenance-Free)	V/Ah	6/12
Charger (Mains Plug-In)	V	230 External

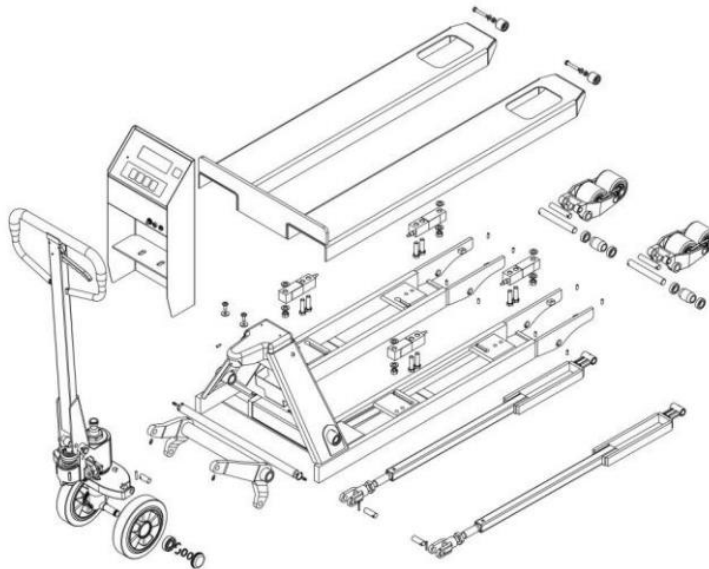
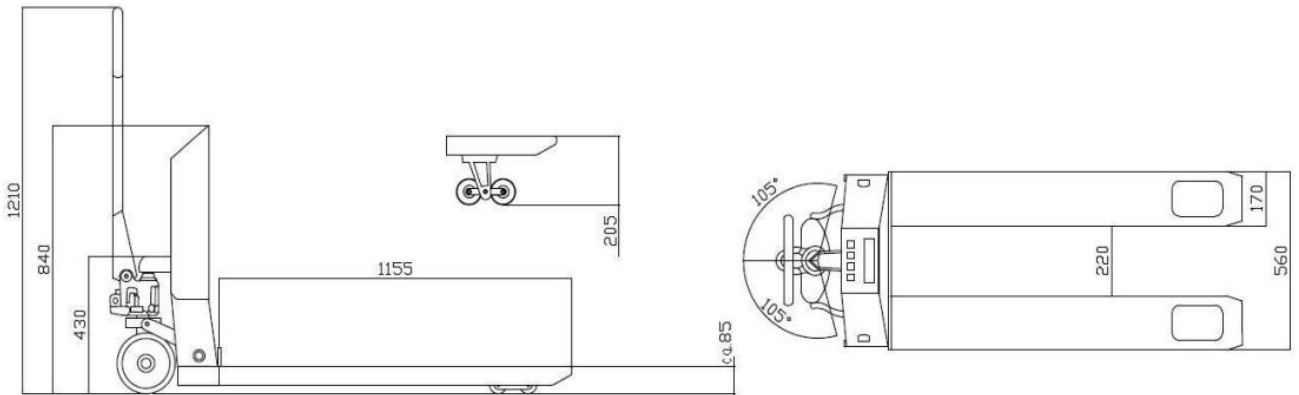

Units 10 & 11 Bridgwater Court, Oldmixon Crescent, Weston-super-Mare BS24 9AY

Tel: 01934 621777 Email: sales@howardhandling.co.uk Web: www.howardhandling.co.uk