

Electric Pallet Trucks

E-Truck Terrain

Lift Capacity: 2000kg

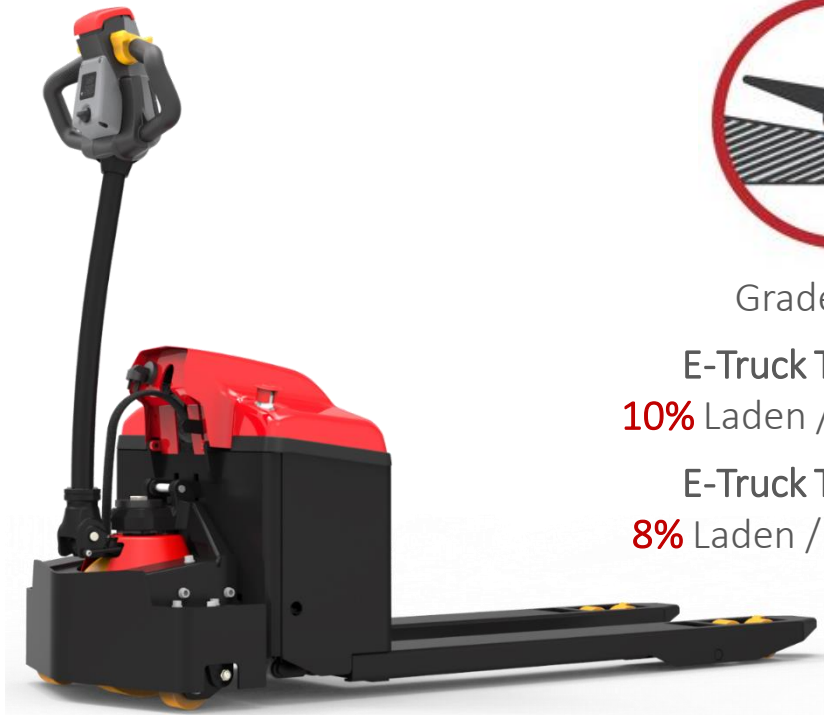

Gradeability:

E-Truck Terrain 1.6t
10% Laden / **20%** Unladen

E-Truck Terrain 2.0t
8% Laden / **16%** Unladen



The tough electric pallet truck for rough & uneven ground, ramps, slopes, inclines & gradients

- DC Power with large 1.6 or 2 tonne lift capacity
- E-Truck Terrain 1.6t is able to traverse a slope of 10% when fully loaded (2.0t model: 8% fully loaded)
- Large 260mm drive wheel; better able to withstand outdoor use on rough and uneven ground
- Solid, durable frame, lift cylinder fitted with incorporated shock absorber
- 48V Brushless drive motor
- Easy to maintain
- Small compact design for agility and use in confined areas
- Ergonomic handle with control buttons positioned to allow operation with either hand

E-Truck Terrain Specification:



Model:	Terrain 2.0	Terrain 1.6
Lift Type:	Fully Powered	Fully Powered
Operation:	Walkie	Walkie
Load Capacity:	2000 Kgs	1600kgs
Truck service weight:	220 Kgs	215kgs
Ground Clearance, Centre of Wheelbase	30mm	30mm
Wheels	PU	Rubber/PU
Forks Lowered:	80mm	80mm
Forks Raised:	220mm	220mm
Overall length:	1685mm	1685mm
Overall width:	560mm	560mm
Outside fork width:	560mm	560mm
Aisle width, 1000 x 1200 UK pallet crossways	1792mm	1792mm
Aisle width, 800 x 1200 Euro pallet lengthways	1992mm	1992mm
Turning radius	1465mm	1465mm
Travel Speed, with load/without load	4/5.5 kmh	4/5.5kmh
Maximum gradeability, with load/without load	8/16%	10/20%
Drive Motor rating S2 60 min	0.75 KW	0.75KW
Battery	48V, Maintenance-Free AGM	48V, Maintenance-Free AGM

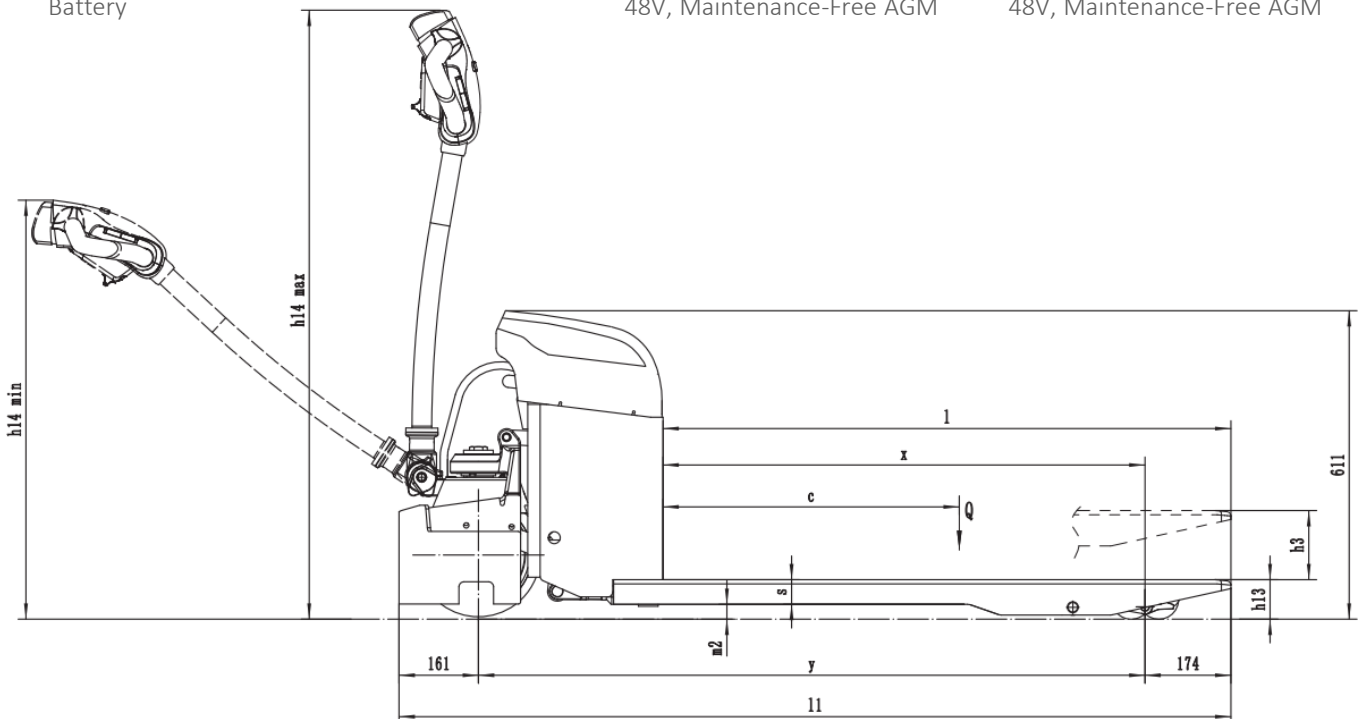

Units 10 & 11 Bridgwater Court, Oldmixon Crescent, Weston-super-Mare BS24 9AY

Tel: 01934 621777 Email: sales@howardhandling.co.uk Web: www.howardhandling.co.uk