

E-Truck Terrain Mk3

1500kg

- ✓ greater water resistance
- ✓ dust resistance
- ✓ & mud resistance



- ✓ solid rubber grooved drive wheel
- ✓ enclosed gearbox

optional



cold store spec

creep (turtle) speed



Designed for applications involving slopes & outdoor use

Enclosed gearbox & connectors provide greater protection against water, dust and mud

Treaded rubber drive wheel for excellent traction on slopes and slippery surfaces

High quality, time tested components for reliability

Maintenance free battery and integrated charger

Higher ground clearance than a standard pallet truck, for use on uneven surfaces

1 year parts & labour warranty

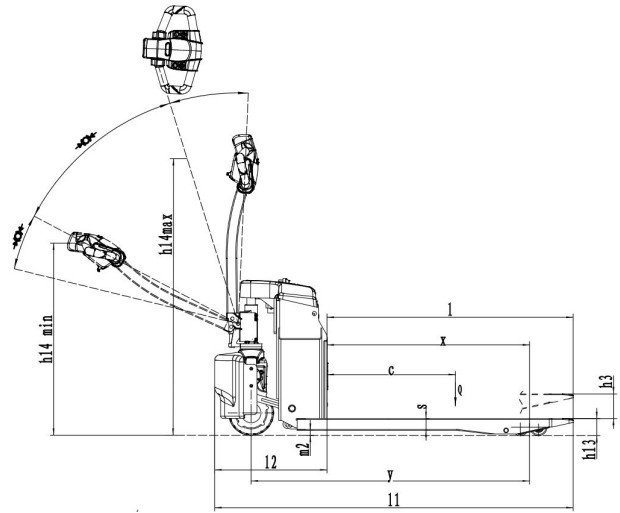
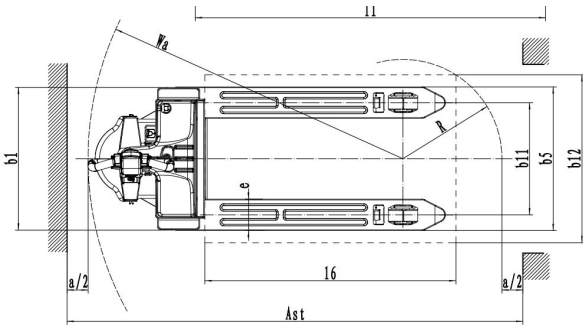

Load Capacity	kg	1500
Service Weight	kg	195
Fork Height, lowered	mm	80
Fork Height, raised	mm	195
Fork Dimensions (H x W x L)	mm	50 x 150 x 1150
Distance Between Fork Arms	mm	560 or 685
Load Centre Distance	mm	600
Overall Length	mm	1673
Overall Width	mm	670 or 685
Travel speed, laden/unladen	km/h	3.8/4
Lifting Speed, laden/unladen	m/s	0.027/0.038
Gradeability, laden/unladen	%	5/16
Battery Voltage/Rated Capacity	v/Ah	24/65
Charger	v/Ah	Internal 24/10
Drive Motor Rating (S2 60 min)	kW	0.75
Lift Motor Rating (S3 15%)	kW	0.8
Ground Clearance, centre of wheelbase	mm	30
Ground Clearance of Drive Cover	mm	50
Service Brake Type		Electromagnetic
Type of Drive Control		DC
Tyre Type driving wheels/loading wheels		Rubber/PU
Sound Level at Driver's Ear	dB (A)	<74